

DESCRIPTION

Automatic Parts Washer

P120 is the optimal system for the automatic washing of medium size mechanical parts. Washing is carried out by the action of upper, lower and side nozzles. Basket rotates through a gear motor; the switchboard is electromechanical. Operators can set the tank liquid temperature as well as the length of the treatment cycle.

- Timed electric exhaustion of steam
- Reinforced basket in electrically welded mesh with external border in galvanized steel
- Hatch closure assisted with gas springs and fastening hook
- Aisi 304 stainless steel filter in pump intake
- Tank border gasket
- Structure and sheet metal in contact with liquid in Aisi 304 stainless steel
- Minimum level switch
- Safety limit switch on cover opening
- Stainless steel electric pump with special seals
- IP65 electrical system, electromechanical controls
- Heating of the liquid with stainless steel electric heating element
- Mechanical rotation of basket via gearmotor
- Internal welding bleaching
- Aisi 304 stainless steel washing pipelines with professional stainless steel flat nozzles
- Drain valves for emptying tanks
- Manual water filling valve



PRODUCT OF ITALY 

Specifications/images subject to change without prior notice. Images are for illustration purposes only. To validate warranty, proof of a valid maintenance contract will be required. Product of Italy 

DESCRIPTION

Accessories Available

- Compressed air blowing (fixed time 3') [B]
- Basket in stainless steel Aisi 304
- Disc oil separator with dedicated motorization
- Kit for use with abrasive contaminants in the washing liquid
- Stainless steel fittings and valves kit (for parts that are in contact with liquids)
- High pressure washing pump
- Panels under the basket with cap filter for collecting grease and chips
- Upper ramp fastened to the cover
- Machine equipped with wheels for handling
- Emptying pump

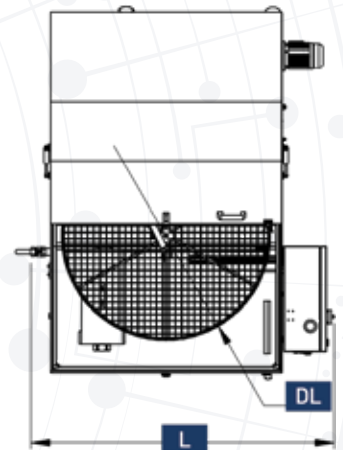
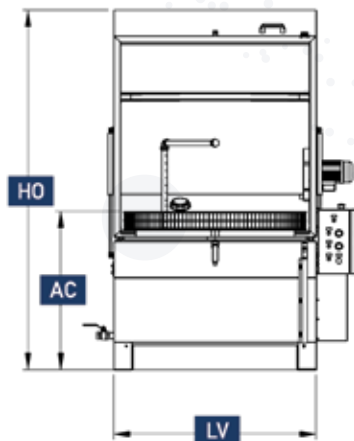
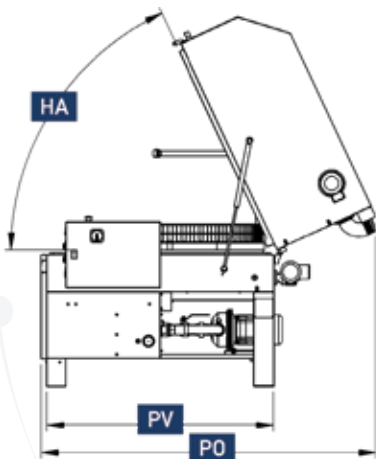
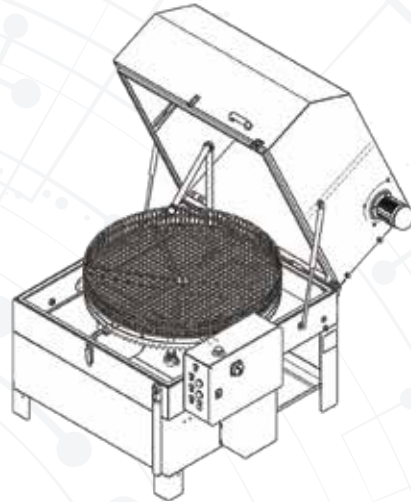

Key	Dimensions and Layout		AC	Loading height	67 cm
L	Width	166 cm	LV	Tank width	130 cm
PO	Depth with opened machine	206 cm	PV	Tank depth	135 cm
HO	Height with opened machine	211 cm	HA	Opening angle	60°
DL	Working diameter	117 cm	W	Weight	202 kg
HL	Washing height	70 cm	RU	Noise LT	75 dBa

PRODUCT OF ITALY 

Specifications/images subject to change without prior notice. Images are for illustration purposes only. To validate warranty, proof of a valid maintenance contract will be required. Product of Italy 

DESCRIPTION

Tech Specs	P120
Load capacity	300 Kg
Tank 1 capacity	270 lt
Pump 1	1,5 kW 2,5 bar 200 lt/min
High pressure pump 1	3,0 kW 6 bar 250 lt/min
Heating tank 1	8 kW
Motor for parts rotation	0,09 kW
Steam exhauster	0,25 kw 320 Nmc/h
Disk oil separator	0,09 kW
Compressed air blowing	150 Nmc/h @ 4 bar
Tank emptying pump	0,37 kW
Power supply	Three-phase

PRODUCT OF ITALY 

Specifications/Images subject to change without prior notice. Images are for illustration purposes only. To validate warranty, proof of a valid maintenance contract will be required. Product of Italy 