

### DESCRIPTION

#### Automatic Parts Washer

This system performs the successful washing of small and medium sized mechanical parts. washing is carried out manually with two gloves in the front part.

The appropriate washing results are ensured by a high pressure pump and a special spray-nozzle. In this configuration (X), the machine is fed by single-phase current. It is then possible to heat the washing pressurised pump up to 80 bar.

- Hatch closure assisted with gas springs and fastening hook
- Black latex gloves 660 mm long
- Tank border gasket
- Structure and sheet metal in contact with liquid in Aisi 304 stainless steel
- Special washing nozzle with jet under pressure and non-slip grip
- Minimum level switch
- LED light to illuminate the inside of the washing area
- Pressure gauge for control of pressure delivered
- Safety limit switch on cover opening
- Pedal-controlled washing action
- Adjustable feet
- IP65 electrical system, electromechanical controls
- Heating of the liquid with stainless steel electric heating element
- Internal welding bleaching
- Drain valves for emptying tanks
- Closing hatch with hoses and tempered glass
- Compressed air blowing gun
- Manually adjustable washing pressure



Tech Specs	X2
Load capacity	70 kg
Tank 1 capacity	50 lt
Pump 1	1,5 kW 80 bar 12,5 lt/min
Heating tank 1	3 kW
Power supply	Single-phase

\*\*\*\*\*  
**PRODUCT OF ITALY** 

Specifications/images subject to change without prior notice. Images are for illustration purposes only. To validate warranty, proof of a valid maintenance contract will be required. Product of Italy 

### DESCRIPTION

#### Accessories Available

- Stainless steel cartridge filter with pump (10/25/50 micron)
- Immersed magnet for separation of ferritic or grinding powder
- High pressure washing gun
- Heating start-up weekly programmer
- Heating with external resistances, not in contact with the liquid
- Machine equipped with wheels for handling
- Increased loading capacity to 150 kg

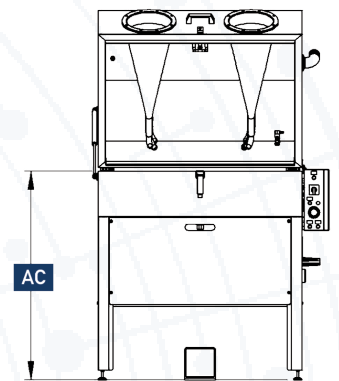
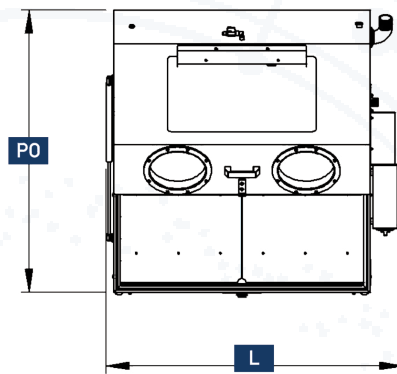
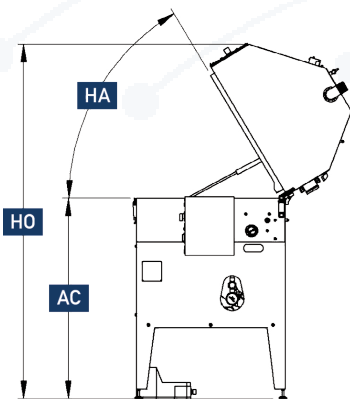

Key	Dimensions and Layout	X2		
L	Width	95 cm	AL	Washing area 70 x 55 cm
D	Depth	66 cm	HL	Washing height 45 cm
PO	Depth with opened machine	98 cm	AC	Loading height 100 cm
H	Height	160 cm	HA	Opening angle 60°
HO	Height with opened machine	170 cm	W	Weight 90 kg
			RU	Noise LT 75 dBa

PRODUCT OF ITALY



Specifications/images subject to change without prior notice. Images are for illustration purposes only. To validate warranty, proof of a valid maintenance contract will be required. Product of Italy